

S27 Strength Requirements for Fore Deck Fittings and Equipment

(Nov 2002)
 (Rev.1 March 2003)
 (Corr.1 July 2003)
 (Rev.2 Nov 2003)
 (Rev.3 July 2004)
 (Rev.4 Nov 2004)
 (Rev.5 May 2010)

1. General

1.1 This UR S 27 provides strength requirements to resist green sea forces for the following items located within the forward quarter length:

air pipes, ventilator pipes and their closing devices, the securing of windlasses.

1.2 For windlasses, these requirements are additional to those appertaining to the anchor and chain performance criteria of each Society.

1.3 Where mooring winches are integral with the anchor windlass, they are to be considered as part of the windlass.

2. Application

2.1 For ships that are contracted for construction on or after 1 January 2004 on the exposed deck over the forward 0.25L, applicable to:

All ship types of sea going service of length 80 m or more, where the height of the exposed deck in way of the item is less than 0.1L or 22 m above the summer load waterline, whichever is the lesser.

2.2 For ships that are contracted for construction prior to 1 January 2004 only for air pipes, ventilator pipes and their closing devices on the exposed deck serving spaces forward of the collision bulkhead, and to spaces which extend over this line aft-wards, applicable to:

Bulk carriers, ore carriers, and combination carriers (as defined in UR Z11) and general dry cargo ships (excluding container vessels, vehicle carriers, Ro-Ro ships and woodchip carriers), of length 100m or more.

2.3 The ship length L is as defined in UR S2.

2.4 This UR does not apply to CSR Oil Tankers.

2.5 The requirements of this UR concerning windlasses do not apply to CSR Bulk Carriers.

3. Implementation

3.1 Ships that are described in paragraph 2.1 that are contracted for construction on or after 1 January 2004 are to comply by the time of delivery.

Note:

1. The "contracted for construction" date means the date on which the contract to build the vessel is signed between the prospective owner and the shipbuilder. For further details regarding the date of "contract for construction", refer to IACS Procedural Requirement (PR) No. 29.
2. This UR does not apply to the cargo tank venting systems and the inert gas systems of tankers.

S27 (cont)

3.2 Ships described in paragraph 2.2 that are contracted for construction prior to 1 January 2004 are to comply:

- i) for ships which will be 15 years of age or more on 1 January 2004 by the due date of the first intermediate or special survey after that date;
- ii) for ships which will be 10 years of age or more on 1 January 2004 by the due date of the first special survey after that date;
- iii) for ships which will be less than 10 years of age on 1 January 2004 by the date on which the ship reaches 10 years of age.

Completion prior to 1 January 2004 of an intermediate or special survey with a due date after 1 January 2004 cannot be used to postpone compliance.

However, completion prior to 1 January 2004 of an intermediate survey the window for which straddles 1 January 2004 can be accepted.

4. Applied Loading

4.1 Air pipes, ventilator pipes and their closing devices

4.1.1 The pressures p , in kN/m^2 acting on air pipes, ventilator pipes and their closing devices may be calculated from:

$$p = 0.5\rho V^2 C_d C_s C_p$$

where:

- ρ = density of sea water (1.025 t/m^3)
- V = velocity of water over the fore deck (13.5 m/sec)
- C_d = shape coefficient
= 0.5 for pipes, 1.3 for air pipe or ventilator heads in general, 0.8 for an air pipe or ventilator head of cylindrical form with its axis in the vertical direction.
- C_s = slamming coefficient (3.2)
- C_p = protection coefficient:
(0.7) for pipes and ventilator heads located immediately behind a breakwater or forecastle,
(1.0) elsewhere and immediately behind a bulwark.

4.1.2 Forces acting in the horizontal direction on the pipe and its closing device may be calculated from 4.1.1 using the largest projected area of each component.

4.2 Windlasses

4.2.1 The following pressures and associated areas are to be applied (see Figure 1):

- 200 kN/m^2 normal to the shaft axis and away from the forward perpendicular, over the projected area in this direction,
- 150 kN/m^2 parallel to the shaft axis and acting both inboard and outboard separately, over the multiple of f times the projected area in this direction, where f is defined as:
 $f = 1 + B/H$, but not greater than 2.5

S27 (cont)

where:

B = width of windlass measured parallel to the shaft axis,

H = overall height of windlass.

4.2.2 Forces in the bolts, chocks and stoppers securing the windlass to the deck are to be calculated. The windlass is supported by N bolt groups, each containing one or more bolts, see Figure 2.

4.2.3 The axial force R_i in bolt group (or bolt) i , positive in tension, may be calculated from:

$$R_{xi} = P_x h x_i A_i / I_x$$

$$R_{yi} = P_y h y_i A_i / I_y$$

$$\text{and } R_i = R_{xi} + R_{yi} - R_{si}$$

where:

P_x = force (kN) acting normal to the shaft axis

P_y = force (kN) acting parallel to the shaft axis, either inboard or outboard whichever gives the greater force in bolt group i

h = shaft height above the windlass mounting (cm)

x_i, y_i = x and y coordinates of bolt group i from the centroid of all N bolt groups, positive in the direction opposite to that of the applied force (cm)

A_i = cross sectional area of all bolts in group i (cm²)

I_x = $\sum A_i x_i^2$ for N bolt groups

I_y = $\sum A_i y_i^2$ for N bolt groups

R_{si} = static reaction at bolt group i , due to weight of windlass.

4.2.4 Shear forces F_{xi} , F_{yi} applied to the bolt group i , and the resultant combined force F_i may be calculated from:

$$F_{xi} = (P_x - \alpha g M) / N$$

$$F_{yi} = (P_y - \alpha g M) / N$$

and

$$F_i = (F_{xi}^2 + F_{yi}^2)^{0.5}$$

where:

α = coefficient of friction (0.5)

M = mass of windlass (tonnes)

g = gravity acceleration (9.81 m/sec²)

N = number of bolt groups.

4.2.5 Axial tensile and compressive forces in 4.2.3 and lateral forces in 4.2.4 are also to be considered in the design of the supporting structure.

S27 (cont)

5. Strength Requirements

5.1 Air pipes, ventilator pipes and their closing devices

5.1.1 These requirements are additional to IACS Unified Requirement P3 and Unified Interpretation LL36 (Footnote *).

5.1.2 Bending moments and stresses in air and ventilator pipes are to be calculated at critical positions: at penetration pieces, at weld or flange connections, at toes of supporting brackets. Bending stresses in the net section are not to exceed $0.8\sigma_y$, where σ_y is the specified minimum yield stress or 0.2% proof stress of the steel at room temperature. Irrespective of corrosion protection, a corrosion addition to the net section of 2.0 mm is then to be applied.

5.1.3 For standard air pipes of 760 mm height closed by heads of not more than the tabulated projected area, pipe thicknesses and bracket heights are specified in Table 1. Where brackets are required, three or more radial brackets are to be fitted. Brackets are to be of gross thickness 8 mm or more, of minimum length 100 mm, and height according to Table 1 but need not extend over the joint flange for the head. Bracket toes at the deck are to be suitably supported.

5.1.4 For other configurations, loads according to 4.1 are to be applied, and means of support determined in order to comply with the requirements of 5.1.2. Brackets, where fitted, are to be of suitable thickness and length according to their height. Pipe thickness is not to be taken less than as indicated in IACS UI LL36.

5.1.5 For standard ventilators of 900 mm height closed by heads of not more than the tabulated projected area, pipe thicknesses and bracket heights are specified in Table 2. Brackets, where required are to be as specified in 5.1.3.

5.1.6 For ventilators of height greater than 900 mm, brackets or alternative means of support are to be fitted according to the requirements of each Society. Pipe thickness is not to be taken less than as indicated in IACS UI LL36.

5.1.7 All component parts and connections of the air pipe or ventilator are to be capable of withstanding the loads defined in 4.1.

5.1.8 Rotating type mushroom ventilator heads are unsuitable for application in the areas defined in 2.

5.2 Windlass Mounts

5.2.1 Tensile axial stresses in the individual bolts in each bolt group i are to be calculated. The horizontal forces F_{xi} and F_{yi} are normally to be reacted by shear chocks. Where "fitted" bolts are designed to support these shear forces in one or both directions, the von Mises equivalent stresses in the individual bolts are to be calculated, and compared to the stress under proof load. Where pour-able resins are incorporated in the holding down arrangements, due account is to be taken in the calculations.

The safety factor against bolt proof strength is to be not less than 2.0.

5.2.2 The strength of above deck framing and hull structure supporting the windlass and its securing bolt loads as defined in 4.2 is to be according to the requirements of each Society.

Footnote *: This does not mean that closing devices of air pipes on all existing ships subject to S27 need to be upgraded to comply with UR P3.

S27
 (cont)

Table 1 : 760 mm Air Pipe Thickness and Bracket Standards

Nominal pipe diameter (mm)	Minimum fitted gross thickness, LL36(c) (mm)	Maximum projected area of head (cm ²)	Height ⁽¹⁾ of brackets (mm)
40A ⁽³⁾	6.0	-	520
50A ⁽³⁾	6.0	-	520
65A	6.0	-	480
80A	6.3	-	460
100A	7.0	-	380
125A	7.8	-	300
150A	8.5	-	300
175A	8.5	-	300
200A	8.5 ⁽²⁾	1900	300 ⁽²⁾
250A	8.5 ⁽²⁾	2500	300 ⁽²⁾
300A	8.5 ⁽²⁾	3200	300 ⁽²⁾
350A	8.5 ⁽²⁾	3800	300 ⁽²⁾
400A	8.5 ⁽²⁾	4500	300 ⁽²⁾

- (1) Brackets (see 5.1.3) need not extend over the joint flange for the head.
- (2) Brackets are required where the as fitted (gross) thickness is less than 10.5 mm, or where the tabulated projected head area is exceeded.
- (3) Not permitted for new ships - reference UR P1.

Note: For other air pipe heights, the relevant requirements of section 5 are to be applied.

Table 2 : 900 mm Ventilator Pipe Thickness and Bracket Standards

Nominal pipe diameter (mm)	Minimum fitted gross thickness, LL36(c) (mm)	Maximum projected area of head (cm ²)	Height of brackets (mm)
80A	6.3	-	460
100A	7.0	-	380
150A	8.5	-	300
200A	8.5	550	-
250A	8.5	880	-
300A	8.5	1200	-
350A	8.5	2000	-
400A	8.5	2700	-
450A	8.5	3300	-
500A	8.5	4000	-

Note: For other ventilator heights, the relevant requirements of section 5 are to be applied.

S27
(cont)

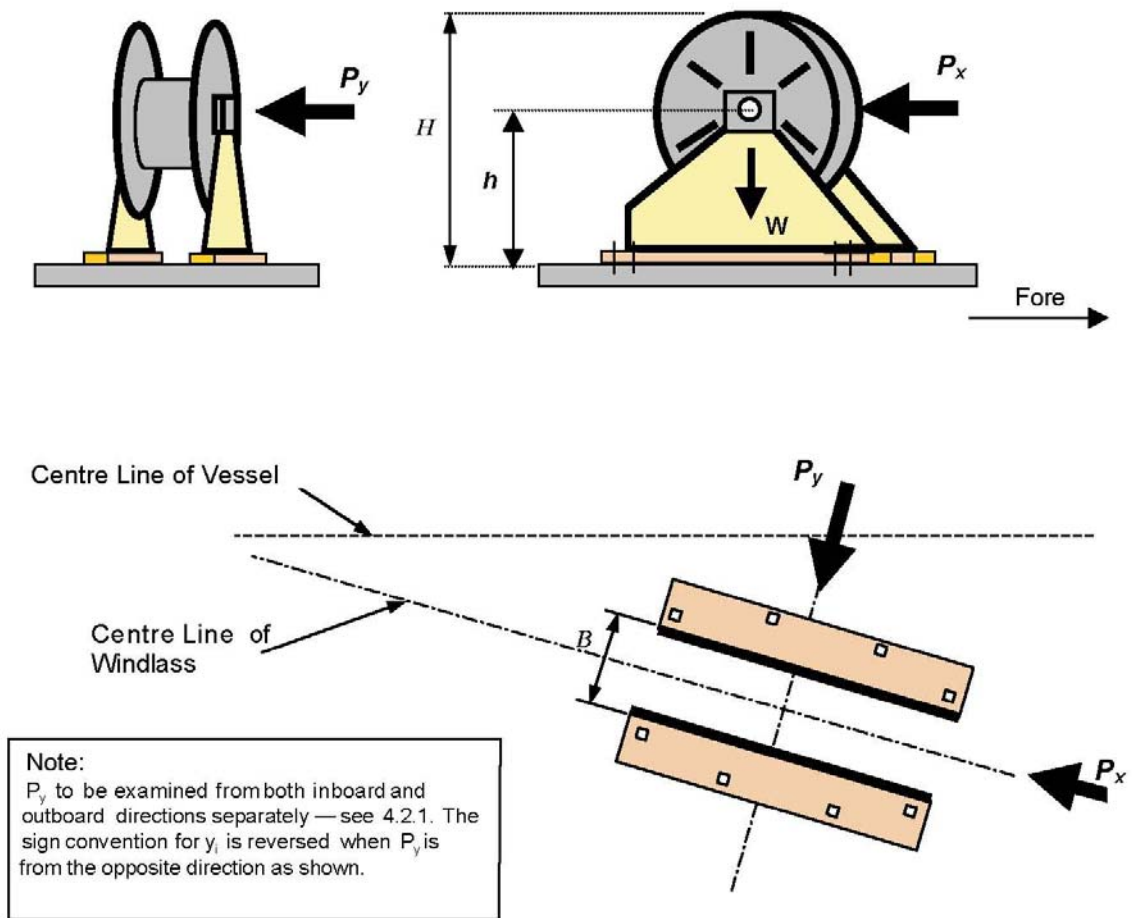

Figure 1. Direction of Forces and Weight

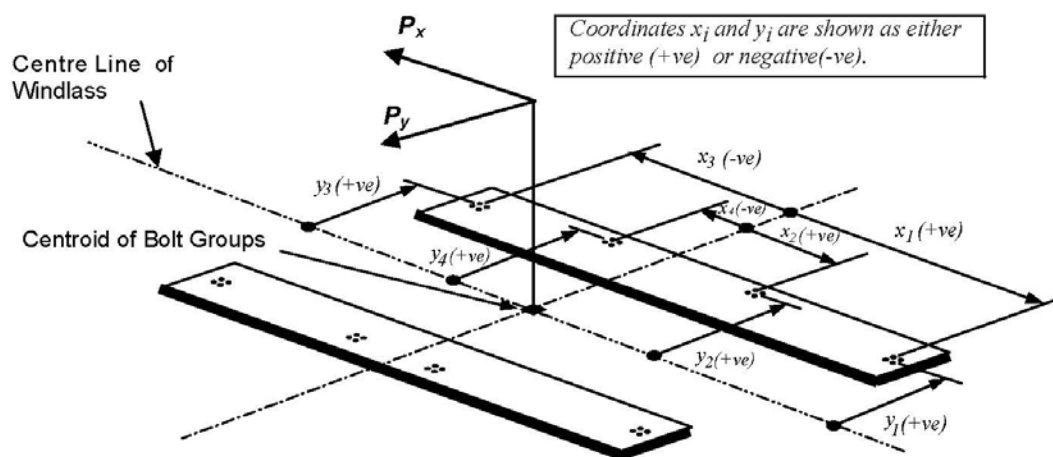

Figure 2. Sign Convention

End of Document