

No.45 Guidelines for Container Corner Fittings

(1996)

1. Scope

1.1 These requirements apply to container corner fittings intended to be used for the fabrication of freight containers.

1.2 The dimensions of the container corner fittings dealt with in these requirements must comply with the latest edition of the International Standard ISO 1161. The Society may require manufacturing drawings to be submitted for approval.

2. Approval

2.1 On agreement with the Classification Society, corner fittings may be manufactured using steel casting and other than casting procedures. For this matter, composite corner fittings may be manufactured using welding.

2.2 The corner fittings are to be manufactured at enterprise approved by the Society. In addition, a special approval test to verify the properties of the materials and welding consumables for container corner fittings is mandatory. The scope of this approval test will be fixed by the Society in each individual case.

2.3 The approval is to be applied for with the Society in writing. The application is to be accompanied by the manufacturer's specification, giving full details of the chemical analysis, mechanical properties, heat treatment and welding procedures when manufacturing and welding repair procedures for the corner fittings.

3. Cast steel corner fittings

3.1 Chemical analysis and deoxydation practice.

The castings are to be manufactured by electric furnace or basic oxygen process, or other processes specially approved by the Society and fully killed. The limiting values for the chemical composition are to comply with Table 1.

Table 1 Chemical composition (ladle analysis)¹⁾

Chemical composition %										
C	Mn	Si	P	S	Cr	Ni	Cu	Mo	Alsol	Cr+Ni+Cu+Mo 2)
max		max	max	max	max	max	max	max	min	max
0,20	0,90 to 1,50	0,50	0,035	0,035	0,25	0,30	0,20	0,08	0,015	0,70
1)	The carbon equivalent $C_{eq} = C + \frac{Mn}{6} + \frac{Cr + Mo + V}{5} + \frac{Ni + Cu}{15} \%$									
2)	Aluminium may be replaced partly or totally by other fine graining elements as stated in the approved specifications.									



No.45

cont'd

3.2 The application of composition of materials other than specified in table 1 (including low-alloyed, carbon-manganese micro-alloyed steels) may be allowed coming into the agreement with the Classification Society provided they are in compliance with the technical specifications and there are confirmations of good weldability.

3.3 Depending on the mechanical characteristics indicated in the Table 2 the chemical composition of steel (including the grain-refining elements) is to be stated in the approved specifications. Additionally the cold cracking susceptibility for evaluating weldability should be calculated from the ladle analysis in accordance with the following formula:

$$CEN(\%) = C + A(C)x \left\{ \frac{Si}{24} + \frac{Mn}{6} + \frac{Cu}{15} + \frac{Ni}{20} + \frac{Cr + Mo + Nb + V}{5} + 5B \right\}$$

The values of A(C) are as follows:

C(%)	0	.08	.12	.16	.20	.26
A(C)	0.500	.584	.750	.916	.980	.998

The maximum admissible value of carbon equivalent CEN is to be agreed with the Classification Society and included in the approved specification.

3.4 Weldability of steel should be demonstrated by the manufacturer during the approval procedure to the satisfaction of the Classification Society.

3.5 When determining the chemical composition of the fittings material the design temperature and the range of ambient temperatures are to be considered to take into account the temperature range during the transportation at different climate conditions. In any case material resistance for the brittle failure should be guaranteed when normally operating at the ambient temperature from -20°C till + 50°C besides the value of impact energy should be in compliance with the table 2. More wide temperature range (lower -20°C and higher +50°C) may be accepted as agreed by the Classification Society and the Client in accordance with the national standards.

3.6 Heat treatment

All castings are to be suitably heat treated.

3.7 Mechanical Properties

The requirements given in Table 2 are to be fulfilled. The values are applicable to specimens taken from separately cast test pieces.



No.45 Table 2 Mechanical Properties

cont'd

Yield strength R_{eH} [N/mm ²] min	Tensile strength R_m [N/mm ²]	Elongation A ₅ [%] min	Reduction of area Z [%] min	Impact Energy KV ¹) (Joule) min at -20°C at -40°C ²)	
220	430 to 600	25	40	27	21
1) Average value on 3 ISO-V-notch impact specimens acc. to UR-W2. One individual value may be below the average value but not lower than 70% of the average. 2) The tests may be carried out at the Client's requests.					

3.8 Freedom from defects

All castings must have a clean surface compatible with the condition of manufacture. Defect liable to impair the use of the fittings, e.g. sizeable non-metallic inclusions, shrinkage cavities, blowholes and cracks are not allowed. They may be removed by one of the procedures mentioned in para 7.

4. Test and inspection

4.1 General requirements

The manufacturer should either be approved on a quality assurance scheme acceptable to the Society or should submit the castings to the individual Society's inspection.

4.2 Chemical analysis

The manufacturer has to determine the chemical composition of each heat.

4.3 Mechanical and impact test

For test sampling the castings are to be grouped into test units originating from the same heat and furnace lot. From each test unit one tensile and one set of notched bar impact test specimens are to be taken and tested. The notched bar impact is to be carried out at -20°C or at -40°C.

4.4 Visual inspection and dimensional checks

The manufacturer is to inspect all castings 100% including dimensional checks and remove defective castings from the consignment. If applicable (cf.4.1) the sound castings are to be presented to the Society's Surveyor for at random inspections.

The dimensions and tolerances of the corner fittings shall conform to figures 1,2,3 and 4.



No.45

cont'd

4.5 Non-destructive inspection

One casting from each heat or from every 400 pieces, whichever is the minimum is to be subjected to a volumetric examination in accordance with an acceptable national standard.

4.6 Test loads

Container corner fittings are to withstand the following design loads calculated in accordance with the requirements of ISO 1496-1 1990 (E) and ISO 1161-1984 E. The tests shall be carried out at 1,5% of each batch of fittings submitted (a batch shall consist of not more than 800 pieces).

4.6.1 Stacking

Top corner fitting
[superimposed load offset 25,4mm (1in)
laterally and 38 mm (1 1/2in)
longitudinally] Design load 848 kN

Bottom corner fitting
(resting on flat support) Design load 954 kN

Bottom corner fitting
[container offset 25,4mm (1 in)
laterally and 38 mm (1 1/2 in)
longitudinally] Design load 848 kN

4.6.2 Lifting

Top corner fitting
(also with hook or shackle) Design load 150 kN

Bottom corner fitting:
slings at 30 to horizontal Design load 300 kN

4.6.3 Longitudinal restraint

Bottom corner fittings
(two fittings carrying loads) Design load 300 kN
(2g x 1R)

4.6.4 Lashing and securing

Top and bottom fittings,
front and side apertures Design load 300 kN
vertically)

Top and bottom fittings,
front and side apertures Design load 150 kN
(horizontally)
(figure 5)



No.45
cont'd

4.6.5 Misgather

Bottom corner fittings

[contact area is 25 mm (1 in) x
6 mm (1/4 in) on the bottom face]
(figure 6)

Design load 150 kN

5. Markings

5.1 Markings by the manufacturer

The castings must be marked at the inside with at least the following symbols:

- Manufacturer's brand mark
- Heat number of abbreviated symbol enabling retracting of the cast
- The Society's classification initials

The above symbols may be cast in at the inner surface of each fitting.

5.2 Surveyor's stamp

The surveyor will stamp every piece inspected by him with his personal stamp.

6. Certificates

For each consignment the manufacturer must supply to the Surveyor a certificate or delivery specification containing at least the following details:

- a) Purchaser and order number
- b) Type of corner casting and cast steel grade
- c) Drawing and/or specification number
- d) Method of manufacture
- e) Heat number and chemical composition
- f) Details of the heat treatment
- g) Number and weight of the castings
- h) Results of inspections and mechanical tests

7. Repair of defects

7.1 Grinding

Minor defects are to be removed by grinding provided the depth below the ground area does not exceed the allowable minus tolerance.



No.45
cont'd

7.2 Welding

Defects, which cannot be removed by grinding may be repaired by grinding or chipping followed by welding, provided their depth does not exceed 40% of the wall thickness and the following conditions are met:

7.2.1 No welding is to be carried out on pieces being in the “as cast” condition.

7.2.2 Preheating to 80-100°C will be necessary if the temperature of the piece is below 5°C or if moisture is present in the weld areas.

7.2.3 The weldings are to be performed by qualified welders in accordance with a qualified welding procedure.

7.2.4 All welded pieces should be subject to post weld heat treatment at about 550°C.

7.2.5 The welded areas are to be ground or machined flush with the adjacent surface and inspected for defects by suitable test methods, e.g. magnetic particle or dye penetrant inspection.



No.45
cont'd

(Dimensions in millimetres)

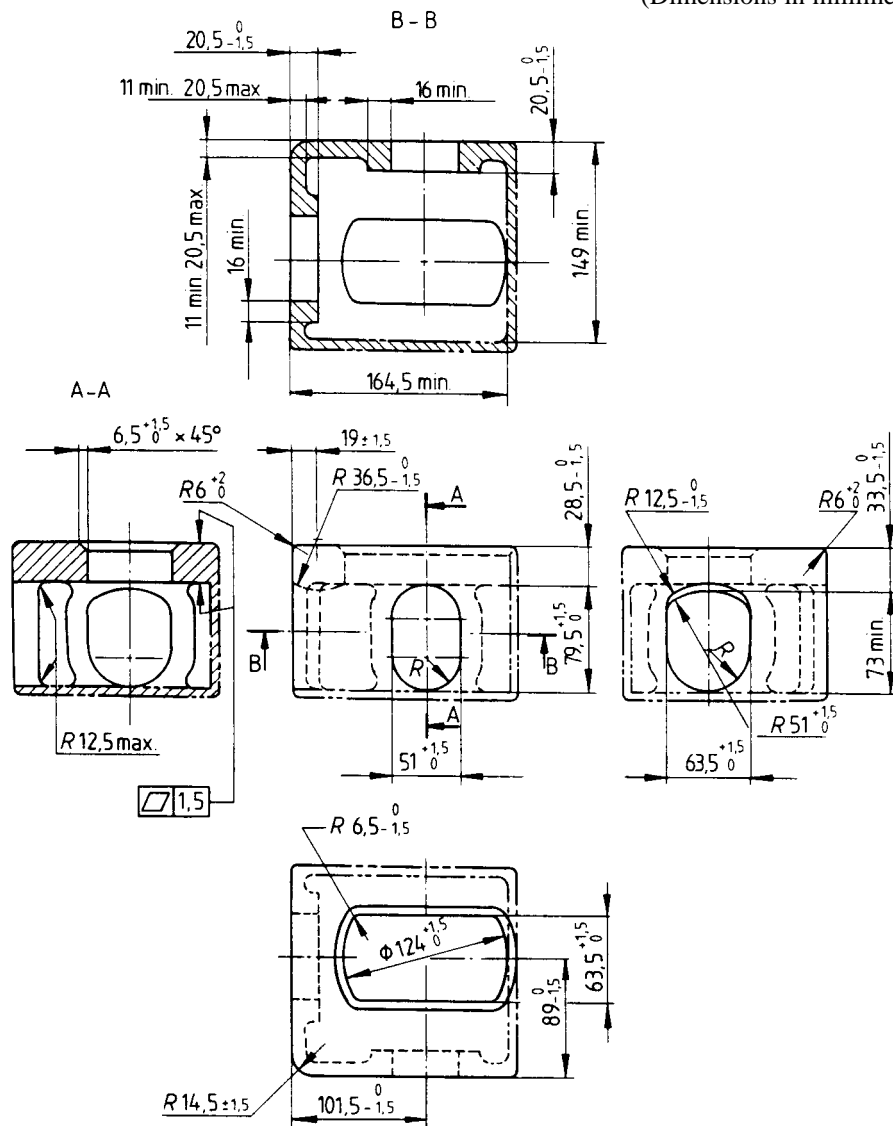

NOTES

- 1 Solid and broken lines (— and ---) show surfaces and contours which shall be physically duplicated in the fitting.
- 2 Phantom lines (— -- — -- —) show optional walls, which may be used to develop a box-shaped fitting.

FIGURE 1 - Top corner fitting - Dimensions in millimetres

No.45
cont'd

Dimensions in inches

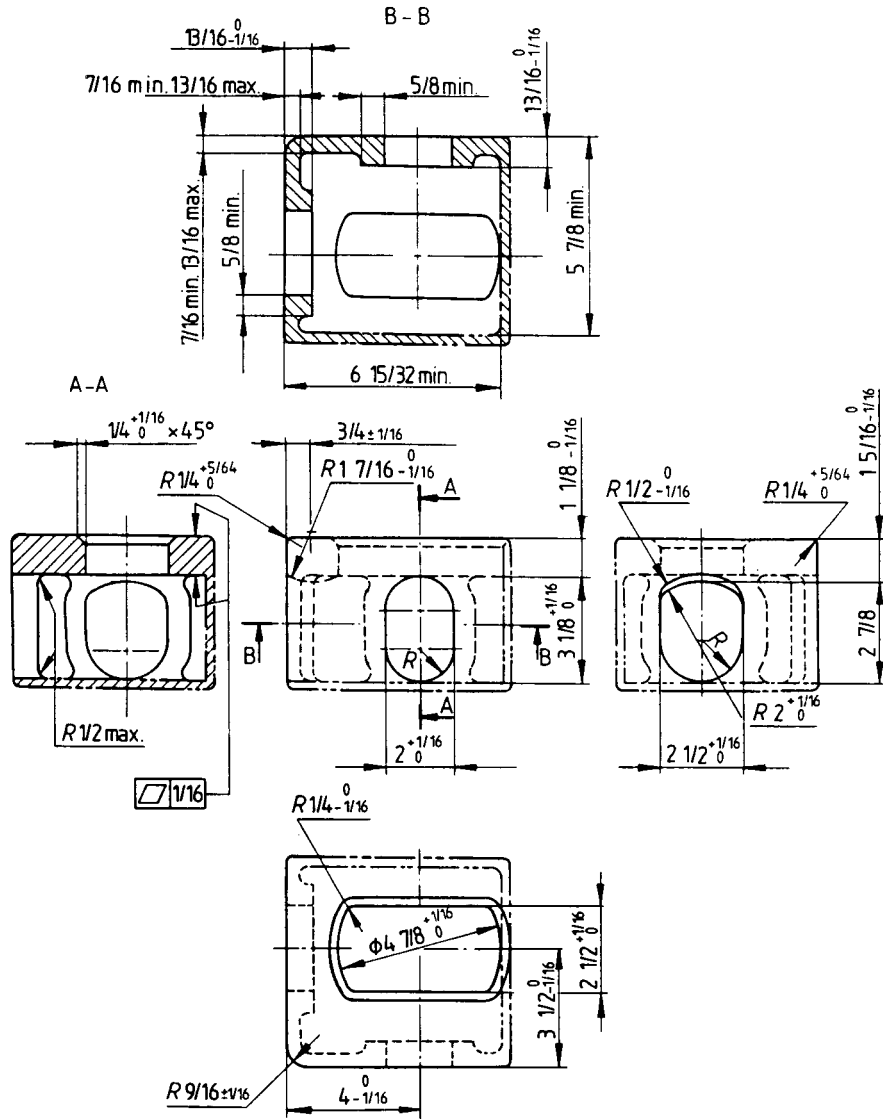

NOTES

- 1 Solid and broken lines (— and ---) show surfaces and contours which shall be physically duplicated in the fitting.
- 2 Phantom lines (— -- — -- —) show optional walls, which may be used to develop a box-shaped fitting.

FIGURE 2 - Top corner fitting - Dimensions in inches

No.45
cont'd

(Dimensions in millimetres)

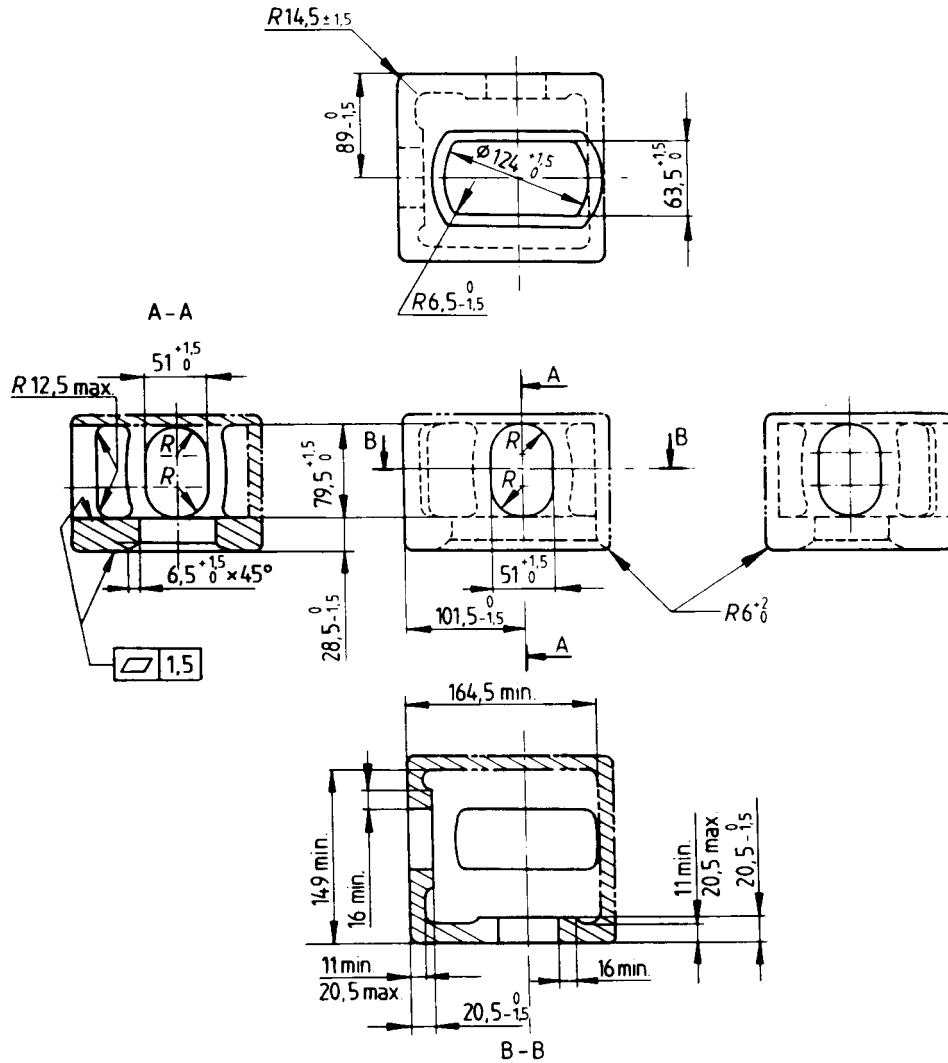

NOTES

- 1 Solid and broken lines (— and ---) show surfaces and contours which shall be physically duplicated in the fitting.
- 2 Phantom lines (— -- — -- —) show optional walls, which may be used to develop a box-shaped fitting.

FIGURE 3 - Bottom corner fitting - Dimensions in millimetres



No.45
cont'd

(Dimensions in inches)

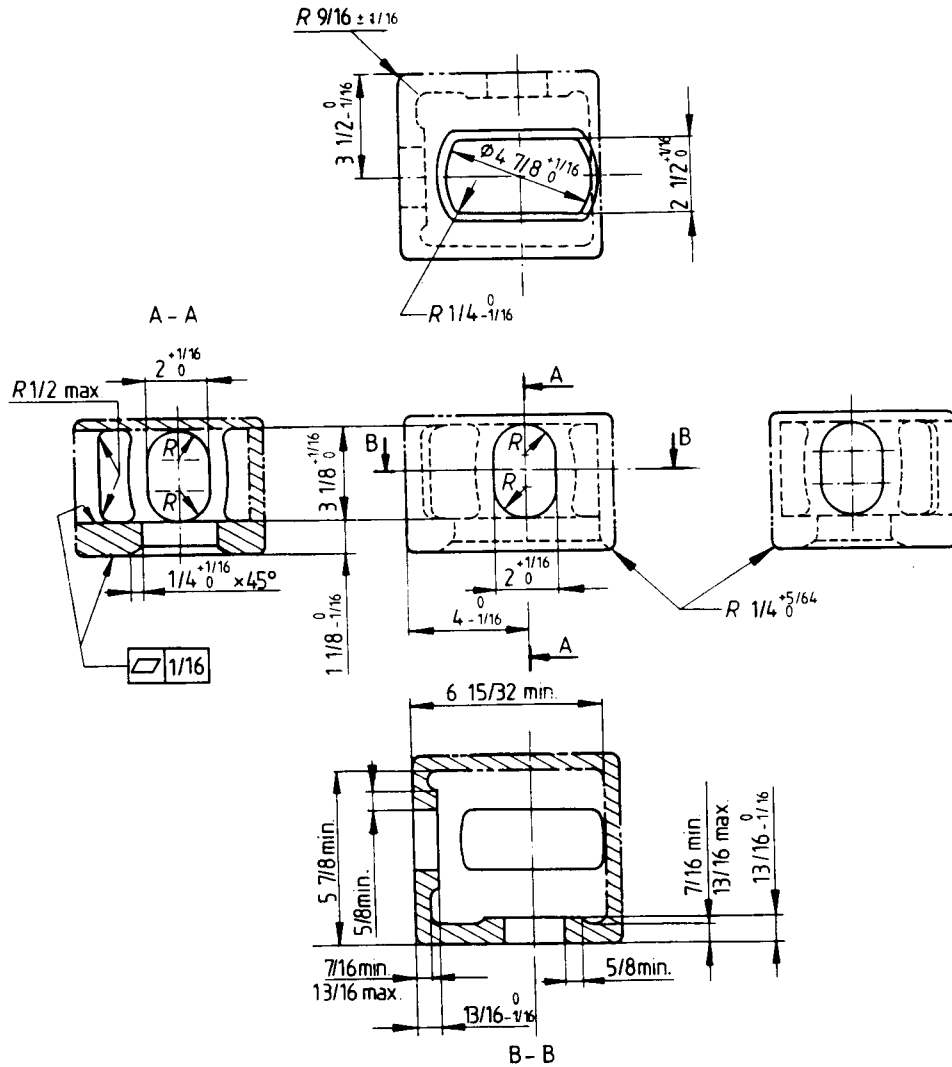

NOTES

- 1 Solid and broken lines (— and ---) show surfaces and contours which shall be physically duplicated in the fitting.
- 2 Phantom lines (— -- — -- —) show optional walls, which may be used to develop a box-shaped fitting.

FIGURE 4 - Bottom corner fitting - Dimensions in inches

No.45
cont'd

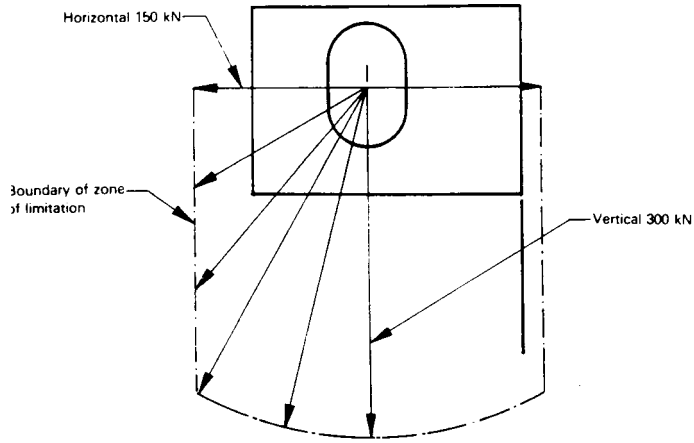

Figure 5 – Limits of loads due to lashing and securing

Figure 5 - Limits of loads due to lashing and securing

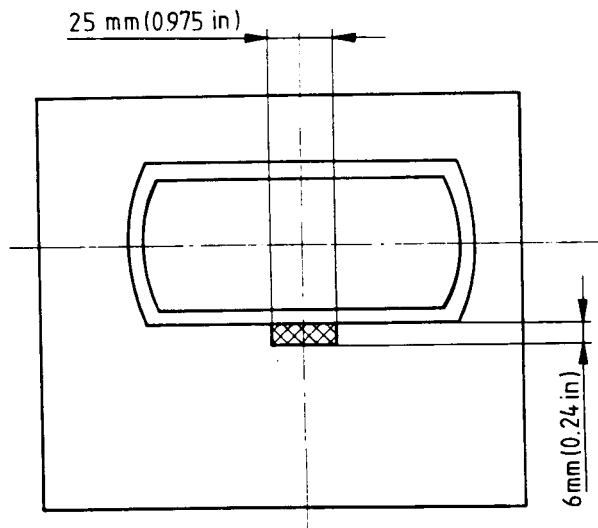

Figure 6 - Bottom view of bottom corner fitting showing contact area (shaded) for misgather (push-up) load



No.45 cont'd

Corner fittings manufactured using welding procedure

8 Scope

8.1 These requirements apply to container composite corner fittings manufactured using welding, namely,

- corner fittings welded totally from rolled or stamped components (sides and edges),
- cast or stamped corner fittings with a welded-in panel (an additional wall which makes the fitting box-like in shape as required by ISO 1161).

9 Requirements for base materials

9.1 Composite corner fittings may be manufactured from combinations of the following materials:

- carbon-manganese steel with a chemical composition in accordance with Table 1 for the manufacture of corner fittings components by casting,
- carbon-manganese micro-alloyed steel, low-alloy steel for the manufacture of corner fitting components from rolled and stamped products.
- application of hull structural steel of appropriate class according to w11, is permitted.

9.2 Steel for corner fitting components assembled from rolled and stamped products and castings by means of welding should be manufactured in accordance with approved national standards and should be supplied fully killed, fine-grain treated and in a heat-treated condition. If the steel for composite corner fittings is manufactured at enterprise other than the fitting the Certificate containing data on chemical composition and mechanical properties of the steel shall be submitted to the surveyor as well as the value of carbon equivalent at his request.

9.3 The content of chemical elements in the steel is to be in accordance with the requirement for the value of the carbon equivalent C_{eq} or C_{EN} in conformity with para 3.1.

9.4 The minimal requirements for the mechanical properties of steel used for composite corner fitting components irrespective of the manufacturing procedure (casting, forging, rolling) are to be in compliance with Table 2.

Forged and rolled steel for composite, fittings shall withstand bending test over the mandrel of thickness equal two thicknesses of metal at the angle of 120°.

9.5 Steels the mechanical properties of which differ from those required above are to be specially approved by the Classification Society.

10. Requirements for welding consumables and welding procedure

10.1 Welding consumables for composite corner fittings are to be approved by the Classification Society and are to comply with standards approved by the Society.



No.45
cont'd

10.2 Welding consumables are to be chosen with regard for the mechanical properties and chemical composition of the base metal and the working temperature range should be taken into consideration, when choosing the base materials as well.

10.3 Welding of composite corner fittings manufactured from cast, stamped and rolled components should be effected with welding consumables of low-hydrogen type. On agreement with the Classification Society, austenitic welding consumables may be used.

In this case, the welding consumables composition is to be chosen in such a way as to eliminate corrosion as a result of an eventual difference of potentials between base metal, heat-affected zone and weld metal.

10.4 The welds of corner fitting components (walls, surfaces) which take up principal loads are to be executed with full penetration.

10.5 The necessity of preheating before welding and of postheat treatment is determined proceeding from the chemical composition of the base and weld metal, procedure of welded fitting components manufacture (casting, forging, rolling).

When manufacturing welded fittings with cast components, the requirements of Section 7.2 should be observed.

10.6 All the welding processes applied by the manufacturer for composite corner fittings are to be approved by the Classification Society proceeding from the results of tests agreed with the Surveyor of the Classification Society and conducted in his presence.

10.7 The welding processes applied by the manufacturer are to comply with the requirements of this Section, with national and international standards which is to be confirmed by the Surveyor of the Classification Society when approving the process.

10.8 All welding operations are to be carried out by certified welders on the basis of national or international standards. The manufacturer's reports of welder certification should be submitted for the consideration of the Classification Society.

11. Testing and inspection when manufacturing

11.1 To test the weld quality of corner fittings, inspections are to be conducted as follows:

- external inspection and measurement,
- non-destructive testing (ultrasonic or radiographic testing as agreed with the Classification Society).

- testing of the mechanical properties of base metal and welded joints,
- testing by working loads in accordance with ISO 1491/1.

The batch of fittings submitted for testing shall include the articles made according to the same technology (of the same material using the same regime of heat treatment and welding etc.)

The number of fittings in the batch shall not be more than 800 pieces.



No.45 cont'd

11.2 100% of corner fittings and their welds should undergo external inspection and measurement. The dimensions and tolerances of the corner fittings shall conform to figures 1,2,3 and 4.

The quality of welded joints is assessed on the basis of national and international standards approved by the Classification Society.

11.3 2% of each batch of corner fittings (for the definition of the batch, see para 4.5), but not less than 3 pieces should undergo ultrasonic or radiographic testing. Quality assessment is effected on the basis of national or international standards approved by the Classification Society. Cracks and lack of penetration in welded joints are not permitted.

If the manufacturer has a quality control system approved by the Classification Society, or if the good quality of fittings manufactured is confirmed during a long period of time, the scope of radiographic (ultrasonic) testing may be reduced or it may be substituted by magnetic particle or dye penetrant testing at the discretion of the Surveyor of the Classification Society.

11.4 Subject to the testing of mechanical properties of base metal and welded joints in fittings is each heat and each batch of fittings which consists of 800 pieces. For this purpose, the following mechanical tests are made:

- tensile test on three weld specimens,
- impact test on three specimens representing the weld metal and three specimens representing the heat-affected zone,
- determining the heat-affected zone hardness on a fillet weld with full penetration revealed on the macrosection.

11.5 The mechanical testing of welds is to be effected on the basis of national or international standards approved by the Classification Society and the yield strength of the weld is not to be less than the corresponding values for the base metal and is to comply with the value contained in Table 2. At the discretion of the Classification Society for confirming the base metal properties the additional specimens may be cut off the fittings for tensile and impact tests. During initial approval the performance of these tests is mandatory.

The impact energy value obtained when testing the weld metal and heat-affected zone must not be less than 27J at a test temperature of -20°C.

The hardness of the weld and heat-affected zone should not exceed 350 HV.

11.6 The testing of a welded corner fitting with working loads should be conducted in conformity with para 4.6.

12 Marking and documentation

12.1 The marking of welded corner fittings and the accompanying documentation as necessary for each batch are to be in compliance with Sections 5 and 6.

